

A Monolithic Thulium Doped Single Mode Fiber Laser with 1.5ns Pulsewidth and 8kW Peak Power

Jianwu Ding^{*a}, Bryce Samson^a, Adrian Carter^a, Chiachi Wang^a, Kanishka Tankala^a
^aNufern, 7 Airport Park Road, East Granby, CT 06026

ABSTRACT

Here we report a compact monolithic 2000nm pulsed laser with a single spatial mode output, ~1.5ns pulse duration, 8kW peak power and >200mW average power at 20 kHz repetition rate. The gain-switched laser, consisting of a pair of fiber Bragg gratings and 0.5m of thulium-doped single cladding fiber, was core pumped by a high peak power pulsed 1.5 μ m laser. When the input pulse energy of the 20 kHz pump pulses was sufficient enough to saturate the Thulium doped fiber, a stable 20 kHz pulse train was observed with measured linewidth of 0.05nm which corresponds to the limit of resolution for the Optical Spectrum Analyzer. This compact, pulsed 2000 nm laser, to the authors' limited knowledge, represents the first Tm-doped fiber laser with 8kW peak power and several ns pulse duration; which is less than the previously reported tens of ns pulsewidth previously reported from gain-switched Tm-doped fiber lasers.

Keywords: thulium doped fiber laser, eye-safe laser, gain-switch, pulse laser

1. INTRODUCTION

The broad emission spectrum of Tm-doped silica fibers has spurred enormous interest in 2 μ m fiber laser development for applications including laser remote sensing, medical laser ablation, counter-measures and high power CW for "eye-safer" laser developments. Wavelength tuning of Tm-fiber lasers has been demonstrated from 1850nm to 2130nm, spanning various gas and water absorption features and extending into useful atmospheric transmission windows. The recent developments in high power 790nm laser diodes and Tm-doped fibers optimized for cross-section energy transfer between Thulium ions have significantly increased the achievable output power of Tm-doped fiber lasers, culminating in the recent demonstration of a 1kW CW Tm-doped fiber MOPA at 2040nm. This work on the Tm-fiber has in turn stimulated intensive development efforts from components manufacturers enabling 2 μ m fiber laser systems to mirror the path of Yb doped fiber lasers towards monolithic, all-fiber systems using gratings, couplers and fiber coupled diodes. In particular, 2 μ m pulsed lasers with ns pulses and kHz repetition rate generated from Tm-doped fiber lasers have been gaining popularity in applications such as laser surgery, multi-photon microscopy, eye-safe LIDAR, laser ranger finders and wavelength conversion to mid- or far-infrared^{1,4}. Various methods of generating pulsed 2 μ m lasers have been reported to date: Q-switched Tm-doped silica fibers to generate relatively longer pulses^{2,3}, ranging from 100ns to several hundred nanoseconds; mode-locked Q-switched Tm-doped fiber laser can generate high repetition and short pulses of picoseconds to several hundred femtoseconds^{6,7}; gain-switched Tm-doped fiber laser can generate 2 μ m pulses with kHz repetition rate and pulsewidth ranging from several tens to 100 ns^{1,5,8}.

Here we report, to the author's limited knowledge, the first demonstration of 2 μ m pulsed laser with 1.5ns pulsewidth and 8kW peak power in a compact monolithic package (6"x6"x2"). The extension of gain switched 2 μ m fiber sources to short pulse durations around 1nsec is particularly interesting, filling a niche caused by the lack of availability of alternatives, such as directly modulated diodes at 2 μ m. Furthermore, the compatibility with this source for further amplification in LMA fiber amplifiers is obviously the next step towards higher pulse energy and peak power with 1nsec pulses at 2 μ m.

2. EXPERIMENTAL SETUP

Due to the rather long relaxation time (>10us) from the 2 μ m emission band, ns or faster gain-switching is difficult to achieve in a Tm-doped fiber laser pumped at 790nm. To overcome this difficulty, gain-switched 2 μ m pulsed lasers are

typically pumped by a high peak power pulsed 1.5 μm fiber laser so as to “resonantly” pump the Tm-doped fiber laser. These fiber sources, based on cladding pumped Er:Yb fibers lasing around 1560nm, have an excellent overlap with the absorption band of the Tm-doped fibers (as shown in Fig. 1). The 1.5 μm pump source typically operates with around 40% slope efficiency and is in turn pumped by high efficiency 9XXnm laser diodes, making the source compact, efficient and monolithic by design. As the gain-switched 2 μm pulses grow from the build-up of the Tm-inversion, the generated 2 μm pulse duration decreases with an increase in the pump pulse energy and a reduction in the cavity length. In this work, a core-pumping scheme was chosen to reduce the Tm- fiber length and enable us to generate shorter 2 μm pulses (~1nsec) than previously reported.

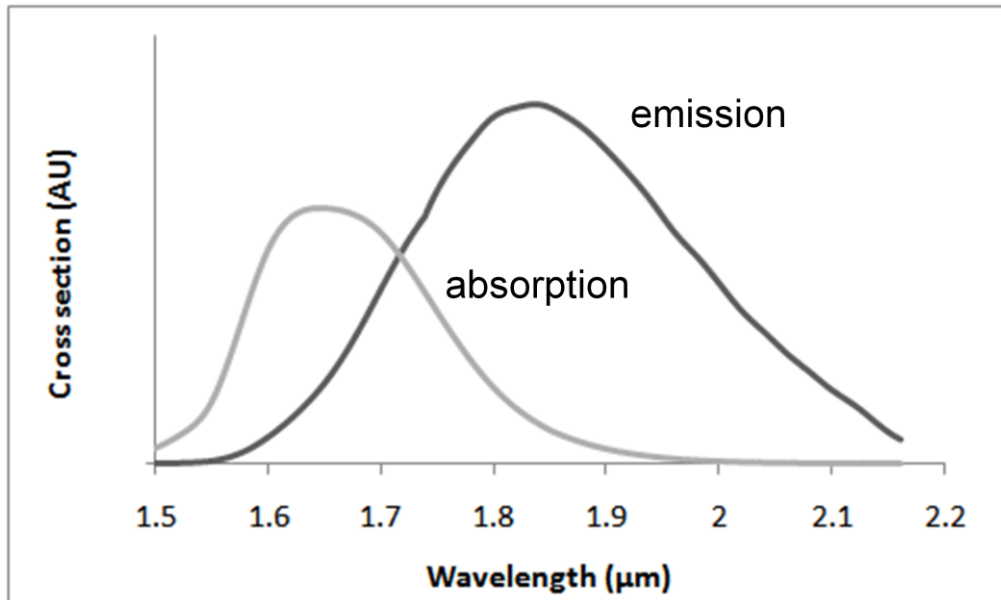

Figure 1: Absorption and emission cross-sections for Tm-doped silica fibers

The gain-switched Tm-doped fiber laser consists of a commercially available 1.5 μm pulsed laser (NuTx from Nufern), a pair of 2000nm fiber Bragg gratings, and a 0.5m length of PM-TSF-9/125 fiber as shown in Figs.2 and 3. The fiber has a cutoff wavelength by design of ~1.75 μm . The 1.5 μm pulsed laser consists of a modulated commercial laser diode to generate the 1.5 μm signal with ns pulse-duration, a two-stage pre-amplifier which is core-pumped by single mode 1480nm diodes and an Erbium and Ytterbium co-doped power-amplifier, cladding pumped at 940nm. The PM-TSF-9/125 fiber is a Tm-doped single clad fiber with a 9 μm core diameter, 0.15 core NA, and an effective mode field diameter of 10.5 μm at 2000nm. The effective pump absorption of the PM-TSF-9/125 fiber is ~12dB/m at the pump wavelength of 1.5 μm . A 1% fiber tap was placed between the pre-amplifier and the power-amplifier of the 1.5 μm pulsed laser to monitor the pre-amplifier output of the NuTx. A dichroic filter was used at the output end to separate the generated 2 μm signal and the residual 1.5 μm pulses, for characterizing the laser output.

The output of the 1.5 μm NuTx was spliced directly onto a highly-reflective (HR) fiber grating with 99% reflectivity at 2000nm, to core-pump the Tm-doped single-cladding fibers. A fiber grating with 15%-reflectivity at 2000nm was used as the output coupler (OC). Various Tm-doped fiber lengths were evaluated over the course of the experiment. In our experience, dropped pulses and unstable pulses were observed when the fiber length is longer than 0.5m. The pulse instability is attributed to the strong re-absorption of the Thulium ions. When the fiber length was less than 0.5m, the average power of the generated 2 μm pulses decreased due to the reduced pump absorption. Therefore, the optimal fiber length for this gain-switched 2 μm pulsed laser was deemed to be ~0.5m. Two fast extended InGaAs detectors (from EO Tech) with 35ps rise and fall time were used to measure the residual 1.5 μm pump and the generated 2.0 μm signal pulses respectively.

Other than the dichroic filter, which was used in free space to analyze the laser performance, the entire system was of a monolithic, all-fiber structure. Furthermore, since there are only three more splices from the output fiber of the 1.5 μ m pulsed pump laser, the entire 2 μ m pulse laser was able to be packaged into the same mechanical housing of the 1.5 μ m NuTx laser. Furthermore the gain-switched 2 μ m pulsed laser utilizes the same electrical control interface as the existing 1.5 μ m NuTx laser.

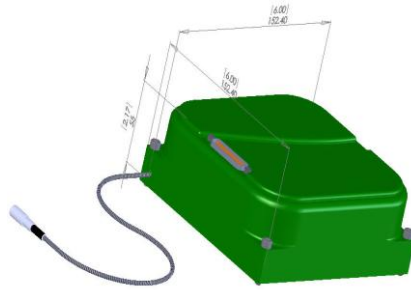

Figure 2: Illustrative CAD drawing of the monolithic 2 μ m pulsed laser.

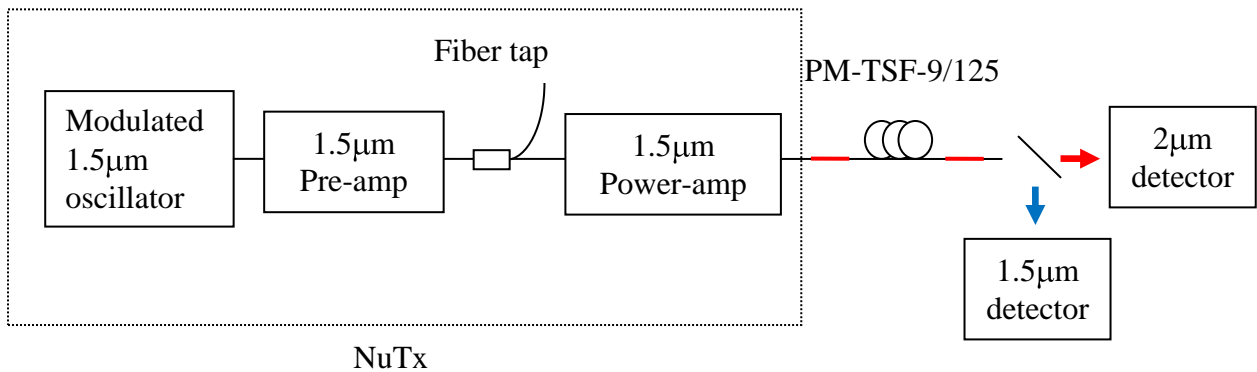

Figure 3: Optical schematics of the monolithic 2 μ m pulsed laser.

3. RESULTS AND DISCUSSIONS

While the repetition rate of the 1.5 μ m pulsed pump laser is adjustable from 20kHz to 500kHz, the average output power of the 1.5 μ m laser varies only slightly from 1W at 20kHz to 1.2W at 500kHz, as the current on the pump diodes is pre-set and not adjustable during the operation. In another words, as the repetition rate increases, the pulse energy and the peak power from the 1.5 μ m pulse laser decreases. While varying the repetition rate of the 1.5 μ m pump laser, it was observed that stable gain switched 2 μ m pulses were only achieved when the pulse repetition rate was set at 20kHz. When the pulse repetition rate is higher than 20kHz, the energy per pulse in the 1.5 μ m pump laser decreases and resulted in dropped 2 μ m pulses and/or pulse instability. Similar behavior was observed when the Tm-doped fiber length exceeded 0.5m and we speculate that the strong re-absorption of the Thulium ions is the cause. In order to have a stable gain-switched 2 μ m pulse, the pump pulse energy has to saturate or bleach through the Tm-doped fiber.

The gain switched Tm-doped fiber laser had a rather high lasing threshold. The onset of lasing was not achieved until the energy of the pump pulses reached 25μJ, or 500mW average power (for pulses with 20kHz repetition rate), which corresponds to 2.5kW for the seed laser pulses at 10ns pulse width, as shown in Fig. 4. It was noticed that the 2μm output became saturated when the 1.5μm pump power reached ~900mW, which corresponds to 4.5kW peak power. At such high peak power, the 1.5μm pump pulses began to generate stimulated Raman scattering which decreased the peak power of pump pulses and resulted in decreased slope efficiency for the 2μm signal.

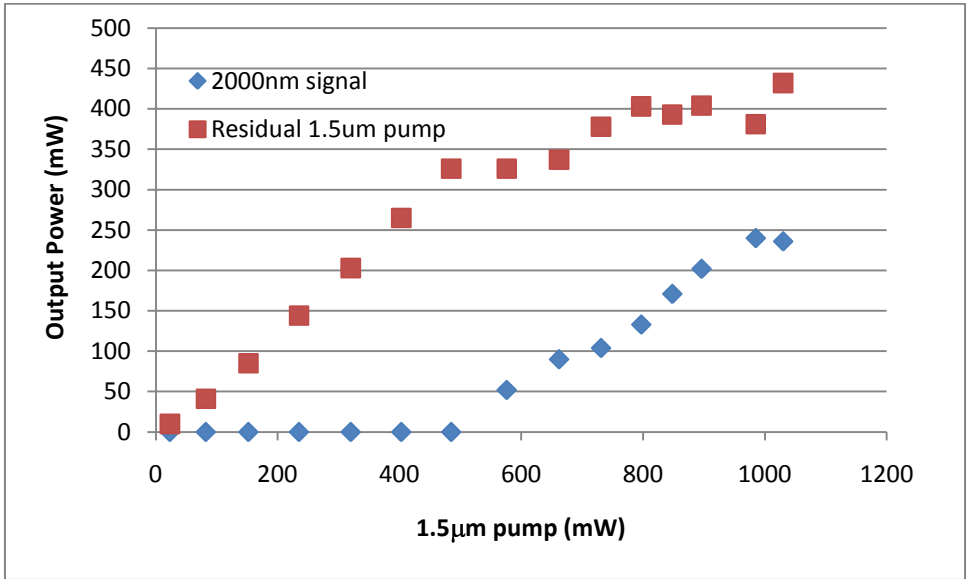

Figure 4: Average Power at 2μm along with the residual 1.5μm pump light from the laser

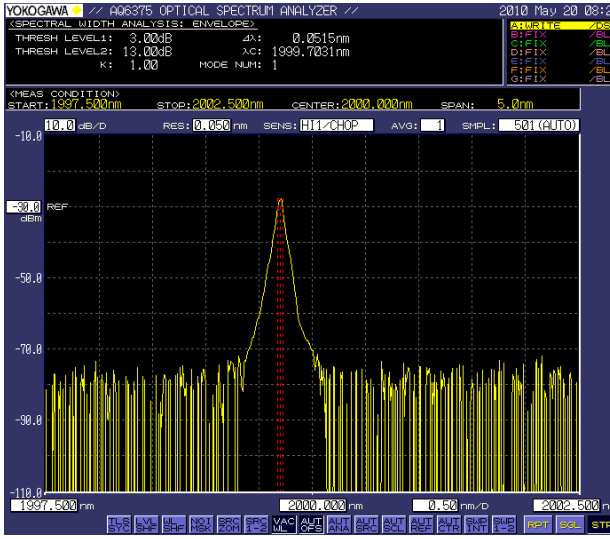

Figure 5: linewidth measurement of the 2μm signal

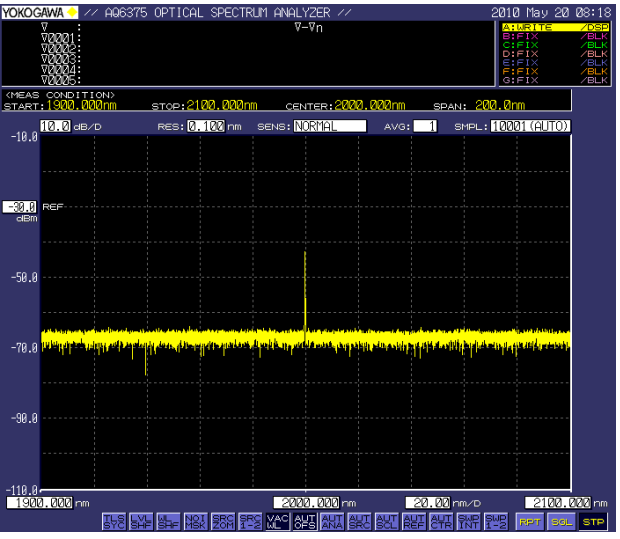

Figure 6: spectrum of the generated 2μm signal

As shown in Fig. 5, the measured 3dB linewidth of the generated $2\mu\text{m}$ signal was 0.05nm , corresponding to $\sim 3.5\text{GHz}$. The linewidth measurement is limited by the minimum resolution (0.05nm) of the Optical Spectrum Analyzer, but we do not expect the output laser linewidth to be less than GHz, as there was no additional wavelength stabilization mechanism implemented in this gain-switched $2\mu\text{m}$ laser. As a result of broader linewidth and short interaction length, no stimulated Brillouin scattering was observed as shown in Fig. 5. In addition, no parasitic lasing or noticeable ASE peak was observed in the wavelength region from 1900nm to 2100nm as shown in Fig. 6. Furthermore, no trace of Raman scattering was found in the optical spectrum, even as the peak power approached 8kW , thanks to the relatively short cavity length and $10.5\mu\text{m}$ mode-field-diameter..

The temporal characteristics of the gain switched fiber laser pulses are shown in Figs. 7 and 8. The pulse-width of the generated $2\mu\text{m}$ signal is $\sim 1.5\text{ns}$, which corresponds to the maximum peak power of 8kW , when the $2\mu\text{m}$ output power saturates at $\sim 220\text{mW}$ output power and around 20kHz repetition rate. To overcome the strong re-absorption from the high dopant concentration of Thulium ions, only 0.5m of PM-TSF-9/125 fibers was used to achieve stable gain-switched pulses and highest power. When the Tm fiber length is longer than 0.5m an unstable mode-locked pulse train was observed, while the repetition rate of the pulse train envelopes either maintained the same repetition rate of the $1.5\mu\text{m}$ pump pulses or half of the repetition rate of the pump pulses, depending on the repetition rate of the $1.5\mu\text{m}$ pump pulses.

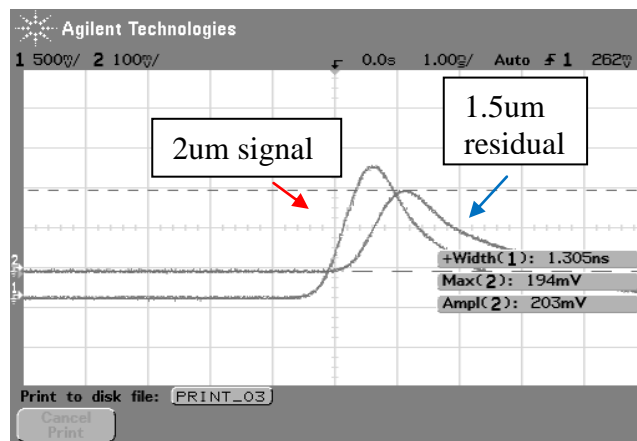

Figure 7: pulsewidth measurement of the generated $2\mu\text{m}$ pulses.

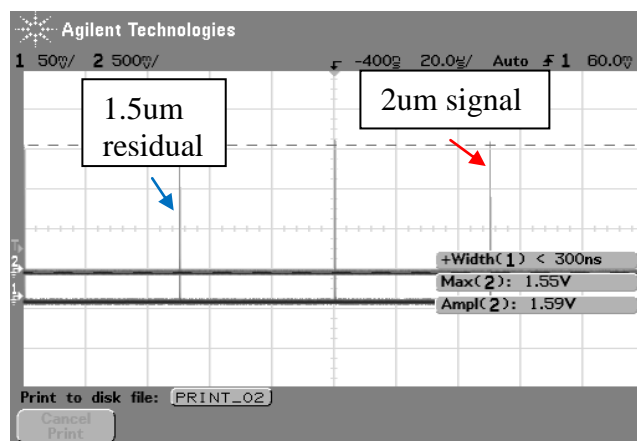

Figure 8: generated $2\mu\text{m}$ pulses at 20kHz repetition rate.

The rather short $2\mu\text{m}$ cavity length means that the pulse build up time is much shorter and overall cavity gain is lower due to the reduced pump absorption. Thus it requires a much higher peak power from the $1.5\mu\text{m}$ pump pulses, 2.5kW peak power of the $1.5\mu\text{m}$ pump pulses in this case, to trigger the $2\mu\text{m}$ pulse generation. On the fast digital oscilloscope, the residual pump pulses were monitored against the generated $2\mu\text{m}$ pulses while the $2\mu\text{m}$ pulses were used as the trigger. Thanks to the rather short cavity buildup time, the generated $2\mu\text{m}$ pulses in fact overlapped with the trailing edge of the pump pulses. As a result, the residual $1.5\mu\text{m}$ pump pulses were observed to be just a little bit behind the generated $2\mu\text{m}$ pulses as shown in Fig. 7. It was also noticed that higher $1.5\mu\text{m}$ pump laser powers, shortened the cavity buildup time, and triggered the earlier occurrence of the $2\mu\text{m}$ pulses.

4. CONCLUSION

In conclusion, we have demonstrated a compact, monolithic $2\mu\text{m}$ pulsed laser with 1.5ns pulsewidth and a maximum of 8kW peak power at a 20 kHz repetition rate. The key difference from the previously reported gain-switched Tm fiber lasers is the adoption of a high peak power (several kW) $1.5\mu\text{m}$ pulsed laser as the pump source which enabled us to generate very short pulses of $\sim 1\text{ns}$ at $2\mu\text{m}$ from a 0.5m long Tm-doped fiber. Furthermore, the results presented here are directly obtained from the gain switched Tm-laser cavity and have not been amplified in an LMA fiber amplifier stage as is commonly performed to achieve such peak powers, though with longer pulses. Further improvements in slope efficiency and various repetition rates are expected with optimization of fiber length and higher Tm-doping concentration. It is also planned to integrate this compact, monolithic gain switched Tm-doped fiber laser with a high power Tm-doped fiber amplifier for further power scaling.

In addition, the unstable mode-locking-like pulse train, observed before the laser reached stable gain-switched operation, suggests that the highly-doped Thulium fibers are capable of operating as a saturable absorber to trigger passive Q-switch or passive mode-locked operation and this behavior will also be further investigated.

5. ACKNOWLEDGEMENT

The authors acknowledge funding for some of this work through a JTO MRI program in collaboration with Clemson University.

REFERENCES

- [1] Moulton, P. F., Rines, G. A., Slobodtchikov, E. V., Wall, K. F., Frith, G., Samson, B., Carter, A., "Tm-doped Fiber Lasers: Fundamentals and Power Scaling", Selected Topics in Quan. Elec., IEEE J. Vol. 15, pp.85-92, (2009)
- [2] Frith, G., Carter, A., Samson, B., Farroni, J., Farley, K., Tankala, K., "Highly Efficient 70W All-fiber Tm-doped Laser System Operating at 1908nm ", Opto-Electronics and Communications Conference, 2008 (2008)
- [3] Christensen, S., Frith, G., Samson, B., "Development s in Thulium-doped Fiber Lasers Offer Higher Powers", 21st annual meeting of the LEOS, IEEE Lasers and Electro-Optics Society, 2008 (2008)
- [4] Jiang, M., Tayebati, P., "Stable 10ns, Kilowatt Peak-power Pulse Generation from a Gain-switched Tm-doped Fiber Laser", Opt. Lett. Vol. 32, No. 13, pp.1797 (2007)
- [5] McComb, T. S., Kadwani, P., Sims, R. A., Shah, L., Willis, C. C., Frith, G., Sudesh, V., Samson, B., and Richardson, M., "Amplification of Picosecond Pulses Generated in a Carbon Nanotube Modelocked Thulium Fiber Laser," in *Advanced Solid-State Photonics*, OSA Technical Digest Series (CD), paper AMB10. (2010)
- [6] Carter, A., Samson, B., Tankala, K., Machewirth, D., Manyam, U., Abramczyk, J., Farroni, J., Guertin, D., Jacobson, N., "The Road to KiloWatt Fiber Laser", Proceeding of SPIE, 2004. **5350**: p. 172-182. (2004)
- [7] Peterka, P., Kasik, I., Matejec, V., Blanc, W., Faure, B., Dussardier, B., Monnom, G., Kubecek, V., "Thulium doped silica based optical fibers for cladding pumped fiber amplifiers", Optical Materials, Vol. 30, Issue 1, pp.174-176 (2007)

- [8] El-Sherif, A. F., King, T. A., "Analysis and Optimization of a Q-switched Operation of a Tm³⁺-doped Silica Fiber Laser Operating at 2 μ m", *IEEE J. Quan. Elec.* Vol. 39, pp 759 (2003)
- [9] El-sherif, A. F., King, T. A., "High-energy, High-brightness Q-switched Tm³⁺-doped Fiber Laser Using an Electro-optic Modulator", *Opt. Commun.* Vol.175, pp337-344 (2003)
- [10] El-sherif, A. F., King, T. A., "High-peak-power Operation of a Q-switched Tm³⁺-doped Silica Fiber Laser Operating near 2 μ m", *Opt. Lett.* Vol. 28, pp22 (2003)
- [11] Desmoulins, S., Di Teodoro, F., "Watt-level, High-repetition-rate, Mid-infrared Pulses Generated by Wavelength Conversion of an Eye-safe Fiber Source", *Opt. Lett.*, Vol.32, pp56 (2007)
- [12] Zhang, Y., Yao, B., Ju, Y., Wang, Y., "Gain-switched Tm³⁺ Doped Double-clad Silica Fiber Laser", *Opt. Exp.* Vol. 13, NO. 4, pp.1085 (2005)
- [13] Nelson, L.E., Ippen, E. P., Haus, H. A., "Broadly Tunable sub-500 fs Pulses From an Additive-pulse Mode-locked Thulium-doped Fiber Ring Laser", *Appl. Phy. Lett.* Vol. 67, pp19 (1995)
- [14] Sharp, R. C., Spock, D. E., Pan, N., "190-fs Passively Mode-lock Thulium Fiber Laser with a Low Threshold", *Opt. Lett.* Vol. 21, pp881 (1996)
- [15] Jackson, S. D., King, T. A., "Efficient Gain-Switched Operation of a Tm-doped Silica Fiber Laser", *IEEE J. of Quan. Elect.*, Vol. 34, pp779 (1998)
- [16] Jackson, S. D., and King, T. A., "Theoretical Modeling of Tm-doped Silica Fiber Lasers", *J. Lightwave Techn.* Vol. 17, pp948-956 (1999)