

56 Sparta Avenue • Newton, New Jersey 07860  
 (973) 300-3000 Sales • (973) 300-3600 Fax  
 www.thorlabs.com



## FC1310-70-10-APC - Feb. 25, 2015

Item # FC1310-70-10-APC was discontinued on Feb. 25, 2015. For informational purposes, this is a copy of the website content at that time and is valid only for the stated product.

- ▶ Designed and Tested for OCT Applications
- ▶ 850 nm or 1310 nm Center Wavelength
- ▶ 99:1, 90:10, or 50:50 Coupling Ratio
- ▶ Polarization Insensitive with Flat Spectral Response

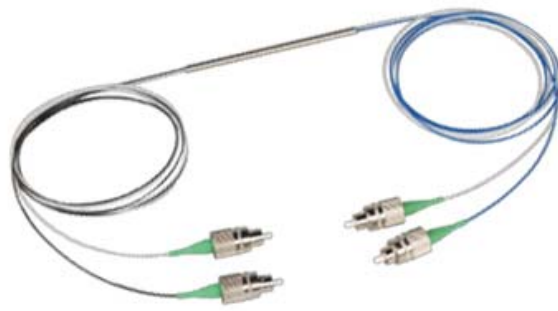

FC850-40-50-APC

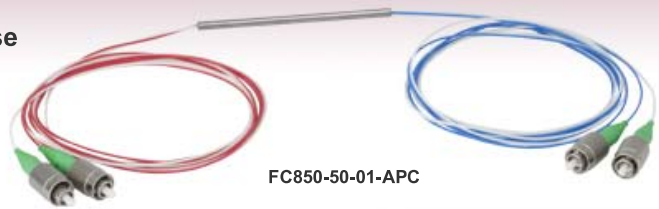

FC850-50-01-APC

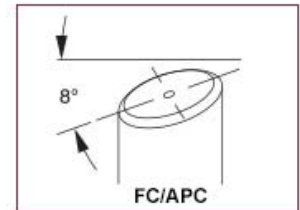

### OVERVIEW

#### Features

- Operating Wavelength Ranges: 850 ± 40 nm, 850 ± 50 nm, or 1310 ± 70 nm
- Flat Spectral Response
- Available Coupling Ratios:
  - 850 ± 40 nm: 50:50
  - 850 ± 50 nm: 99:1 and 90:10
  - 1310 ± 70 nm: 99:1, 90:10, and 50:50
- 2.0 mm Narrow Key FC/APC Connectors
- Individual Test Report Included with Each Coupler
- Customized Fiber Lead Lengths and Connectors Available

Fiber optic couplers are devices with more than one input and output fiber. The couplers sold here have 2 input and 2 output single mode fibers, as shown in the photo to the right. Light input into the device from a single fiber on one end is coupled, at a fixed ratio, into the other set of leads.

For example, light input into lead A<sub>1</sub> of the FC1310-70-01-APC

coupler will be split so that 99% of the transmitted light is coupled into the B<sub>2</sub> lead while the other 1% is coupled into the B<sub>1</sub> lead. The coupler is bidirectional, in that you can input the light into any of the fiber leads and have the transmitted light split between the two leads in the other lead pair.

For our full selection of fiber optic couplers, please see our Fiber Optic Couplers guide.

Optical Coherence Tomography (OCT) systems require components that operate over a broad spectral range with minimal spectral dependency. Thorlabs' OCT-proven couplers are tested to ensure minimal wavelength-dependent insertion loss variations, making them an ideal choice for integration into many OCT systems. These OCT-proven broadband couplers are polarization independent, passive, 2 x 2 single mode fiber optic components designed for use over larger bandwidths. An important consideration in the design of an OCT system is the flat spectral response of the components in the system. The spectral response curves for these couplers are shown on the *Verification Testing* tab.



Click to Enlarge

### VERIFICATION TESTING

#### Verification Test Procedure

A broadband light source is spectrally analyzed, and the trace is saved as Reference 'A' (blue in Figure 1 below). Next, this reference light is sent to the coupler; the output of the coupler is analyzed and saved as trace 'B' (red in Figure 1 below). These two traces are shifted so that their peak value is 0 dB in order that they share a common reference intensity (Figure 2). The difference ('A-B') between these two traces is calculated as a function of wavelength and plotted in green in Figure 3 below. The result is the spectral uniformity curve for the fiber coupler, showing the variation in transmitted intensity as a function of wavelength for the

specified operating range of the fiber coupler.

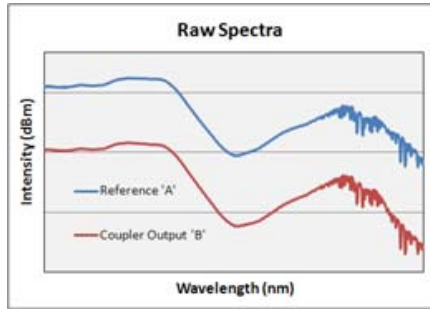
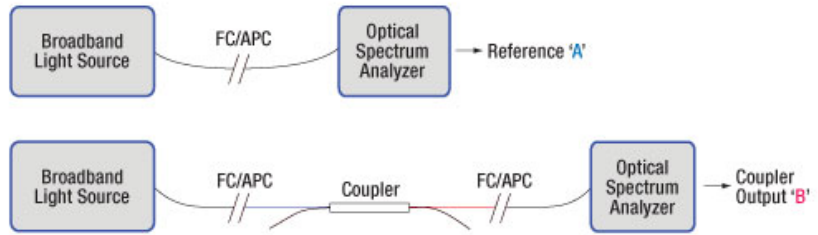

Figure 1

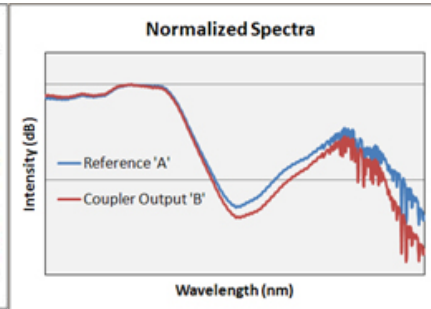

Figure 2

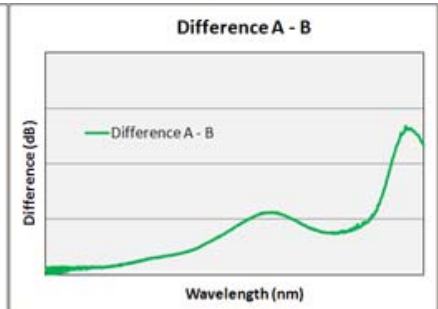

Figure 3

**Test Results**

Each possible optical path is analyzed for the wavelength dependence of the coupling ratio, yielding 4 traces for each coupler as shown in the sample plots below. Every OCT fiber coupler placed in inventory is tested to ensure that it meets the criteria listed below.

**FC850-40-50-APC**

- Region Analyzed: 850 ± 40 nm
  - Maximum Variation from 0 dB: 2.0 dB
- Region Analyzed: 850 ± 20 nm
  - Maximum Variation from 0 dB: 1.3 dB

**FC1310-70-xx-APC**

- Region Analyzed: 1310 ± 70 nm
  - Maximum Variation from 0 dB: 1.5 dB
- Region Analyzed: 1310 ± 50 nm
  - Maximum Variation from 0 dB: 1.0 dB

**FC850-50-xx-APC**

- Region Analyzed: 850 ± 50 nm
  - Maximum Variation from 0 dB: 1.5 dB
- Region Analyzed: 850 ± 25 nm
  - Maximum Variation from 0 dB: 1.0 dB

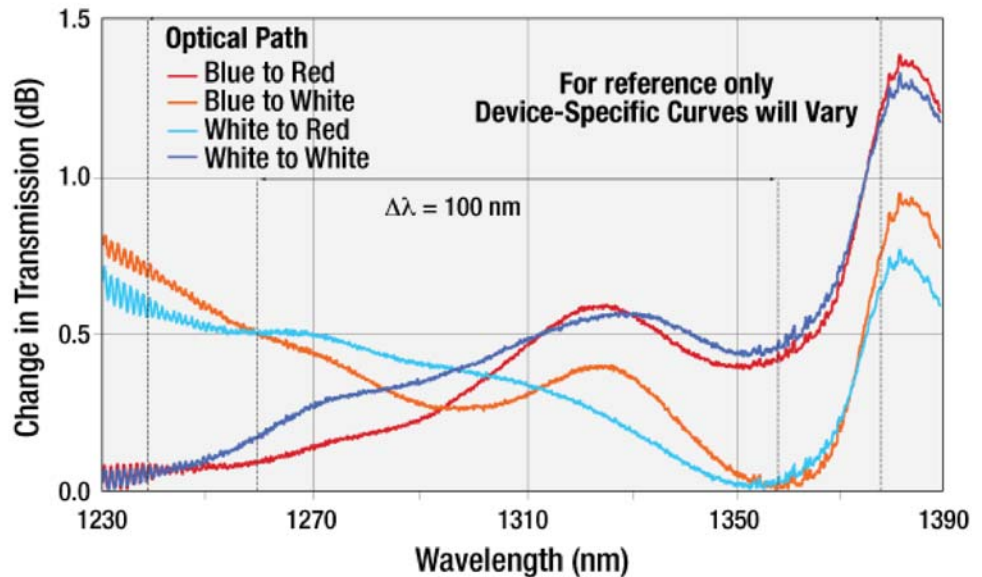

Click to Enlarge



Click to Enlarge  
 FC1310-70-50-APC Coupler  
 The colored leads are referenced in the plot to the right.

COUPLING EXAMPLE

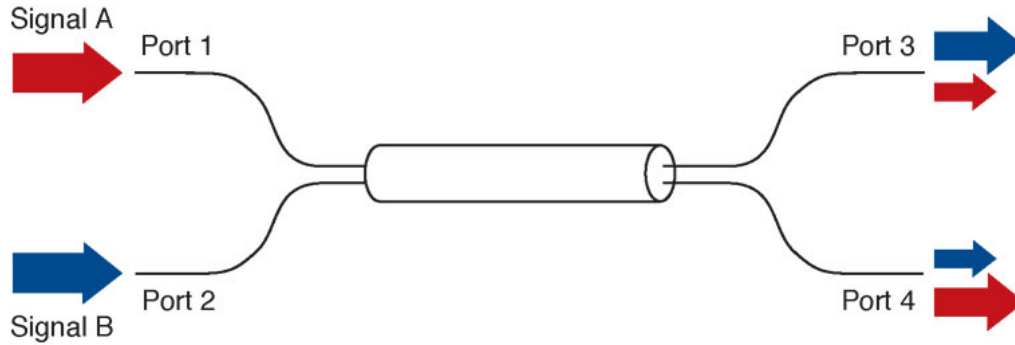

Figure does not represent a specific coupling ratio, for demonstrational purposes only.

In the example below, a 10202A 2x2 Coupler is used with Signal A at a wavelength of 1550 nm and Signal B at a wavelength of 1540 nm. Please refer to the picture above for port numbers and signal paths. Expected output is summarized in the table below for various setups.

One Port Signal Tapping of Signal A

Coupling Ratio	Input Signal		Output Signal			
	Port	Power	Port	Power	Port	Power
50/50	1	10 dBm	3	6.2 dBm	4	6.2 dBm
90/10	1	10 dBm	3	-2.7 dBm	4	9.2 dBm
99/1	1	10 dBm	3	-11.6 dBm	4	9.6 dBm

Two Port Signal Mixing of Signals A and B

Coupling Ratio	Input Signal				Output Signal			
	Port	Power	Port	Power	Port	Power	Port	Power
50/50	1	5 dBm	2	8 dBm	3	Signal A: 1.2 dBm Signal B: 4.2 dBm	4	Signal A: 1.2 dBm Signal B: 4.2 dBm
99/1	1	5 dBm	2	8 dBm	3	Signal A: -16.6dBm Signal B: 7.6dBm	4	Signal A: 4.6dBm Signal B: -13.6 dBm

Coupling a Return Signal with a Reflector on Port 3 of Signals A and B

Coupling Ratio	Input Signal				Output Signal			
	Port	Power	Port	Power	Port	Power	Port	Power
90/10	1	6 dBm Reflected Signal A: -19.4 dBm	2	0 dBm Reflected Signal A: -7.5 dBm	3	Signal A: -6.7 dBm (reflected back into coupler)	4	Signal A: 5.2 dBm

DEFINITIONS

Explanation of Selected Specifications

This tab provides a brief explanation of how we determine several key specifications for our 2x2 couplers. The legs of the coupler are defined as shown in the diagram below.

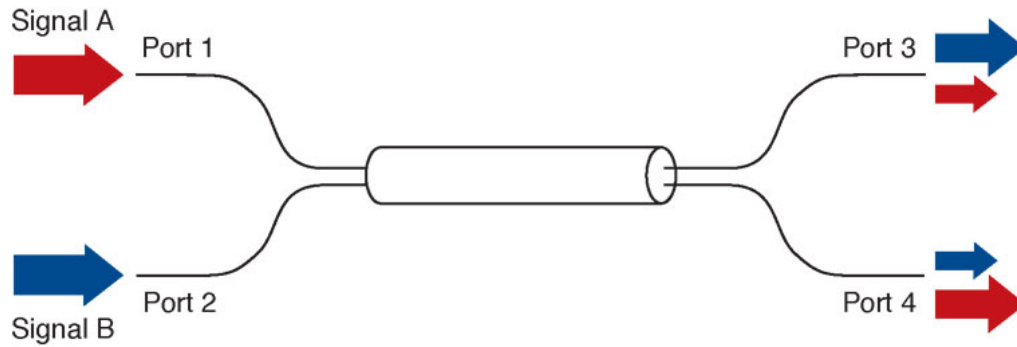

Figure does not represent a specific coupling ratio (for demonstrational purposes only)

#### Excess Loss

Excess loss in dB is determined by the ratio of the total output power to the total input power:

$$\text{Excess Loss}(dB) = -10 \log \left( \frac{P_{port3}(mW) + P_{port4}(mW)}{P_{port1}(mW)} \right)$$

$P_{port1}$  is the input power at port 1 and  $P_{port3}+P_{port4}$  is the total output power from Ports 3 and 4, assuming no input power at Port 2. All powers are expressed in mW.

#### Directivity (or Return Loss)

The return loss in fiber optic couplers is typically referred to as the directivity and can be calculated in units of dB using the following equation:

$$\text{Directivity}(dB) = 10 \log \left( \frac{P_{port1}(mW)}{P_{port2}(mW)} \right)$$

The fraction in the logarithm is the ratio of the input power at port 1 to any output power detected at port 2. This output is the result of some back reflection at the junction of the legs of the coupler and represents a loss in the total light output at ports 3 and 4. All powers are expressed in mW.

#### Insertion Loss

The insertion loss is determined by the ratio of the input power to the output power from one leg of the coupler. It can be generally written as

$$\text{Insertion Loss}(dB) = 10 \log \left( \frac{P_{in}(mW)}{P_{out}(mW)} \right)$$

where the powers are in mW and the resulting insertion loss is in dB. To use a more specific example, the insertion loss of a signal from Port 1 to Port 3 may be written as

$$\text{IL From Port 1 to Port 3}(dB) = 10 \log \left( \frac{P_{port1}(mW)}{P_{port3}(mW)} \right)$$

and the insertion loss from Port 1 to Port 4 as

$$\text{IL From Port 1 to Port 4}(dB) = 10 \log \left( \frac{P_{port1}(mW)}{P_{port4}(mW)} \right)$$

Similar equations can be formulated using Port 2 as the input arm.

Insertion loss can also be easily calculated with the power expressed in units of dBm. The power in mW is related to the power in dBm using the equation:

$$P(mW) = 10^{\frac{P(dBm)}{10}}$$

Then, the insertion loss in dB can be calculated as follows:

$$\text{Insertion Loss}(dB) = P_{in}(dBm) - P_{out}(dBm)$$

### 850 nm OCT Broadband Fiber Optic Couplers



Item #	FC850-50-01-APC	FC-850-50-10-APC	FC850-40-50-APC
Wavelength Range	850 ± 50 nm		850 ± 40 nm
Fiber Type	780HP with Ø900 µm Hytel Tubing		
Coupling Ratio (%)	99:1	90:10	50:50
Insertion Loss <sup>a</sup>	0.4/22 dB	0.9/13 dB	4.2/4.2 dB
Polarization-Dependent Loss	0.2 dB		
Excess Loss <sup>a</sup>	0.5 dB		1.0 dB
Directivity <sup>a</sup>	55 dB		
Port Configuration	2 x 2		
Operating Temperature Range	-40 to 85 °C		
Storage Temperature Range	-40 to 85 °C		
Lead Length and Tolerance	1 m +0.075 m/-0.0 m		
Connectors	2.0 mm Narrow Key FC/APC		

- Please see the *Definitions* tab for details.

Part Number	Description	Price	Availability
FC850-50-01-APC	2x2 Broadband SM Coupler, 850 ± 50 nm, 99:1 Split, FC/APC	\$260.10	Today
FC850-50-10-APC	2x2 Broadband SM Coupler, 850 ± 50 nm, 90:10 Split, FC/APC	\$260.10	Today
FC850-40-50-APC	2x2 Broadband SM Coupler, 850 ± 40 nm, 50:50 Split, FC/APC	\$260.10	Today

**1310 nm OCT Broadband Fiber Optic Couplers**

Item #	FC1310-70-01-APC	FC1310-70-10-APC	FC1310-70-50-APC
Wavelength Range	1310 ± 70 nm		
Fiber Type	SMF-28e+ with Ø900 µm Hytrel Tubing		
Coupling Ratio (%)	99:1	90:10	50:50
Insertion Loss <sup>a</sup>	0.4/21.6 dB	0.8/12.7 dB	3.8/3.8 dB
Polarization-Dependent Loss	0.15 dB		
Excess Loss <sup>a</sup>	0.5 dB		
Directivity <sup>a</sup>	60 dB		
Port Configuration	2 x 2		
Operating Temperature Range	-40 to 85 °C		
Storage Temperature Range	-40 to 85 °C		
Lead Length and Tolerance	1 ± 0.10 m		
Connectors	2.0 mm Narrow Key FC/APC		

- Please see the *Definitions* tab for details.

Part Number	Description	Price	Availability
FC1310-70-01-APC	2x2 Broadband SM Coupler, 1310 ± 70 nm, 99:1 Split, FC/APC	\$260.10	Today
FC1310-70-10-APC	2x2 Broadband SM Coupler, 1310 ± 70 nm, 90:10 Split, FC/APC	\$260.10	Today
FC1310-70-50-APC	2x2 Broadband SM Coupler, 1310 ± 70 nm, 50:50 Split, FC/APC	\$260.10	Today

Visit the *OCT Fiber Optic Components* page for pricing and availability information:

[http://www.thorlabs.com/newgrouppage9.cfm?objectgroup\\_id=2865](http://www.thorlabs.com/newgrouppage9.cfm?objectgroup_id=2865)